



**TELEDYNE  
DEFENCE**

A Teledyne Technologies Company

## 2-18GHz Radar Warning Receiver

**RR017**



### Features

- Frequency range 2 to 18 GHz
- 25MHz Frequency resolution
- 0.2dB Amplitude resolution
- Pulse Descriptor Word Output
- USB2 interface
- Sensitivity -60dBm Typ
- Small form factor
- Standby Mode

### Applications

- Radar Warning Receiver for:
  - AFV
  - UAV
- Remote sensing
- Affordable RWR for air, sea and land platforms

## Product Description

The RR017 is designed for Radar Warning Receiver (RWR) applications where low cost and small size and are of prime importance, with filtering, amplification, detection and pulse parameter measurement being combined into one multi-function unit.

Two amplitude measurement channels allow direction finding by amplitude comparison between adjacent antennas. A 20dB switched attenuator can be selected to allow amplitude measurement above -15dBm. An IFM, fed from one of the amplitude channels via an SPDT switch, performs 10 bits of frequency measurement on the selected input. Frequency resolution is nominally 25 MHz over a 2 to 18 GHz band.

The RR017 is internally triggered and generates a full PDW giving the following data; Time of arrival, pulse amplitude (from the two selected antennas), pulse frequency and pulse width.

The standard data interface is USB2 with optional 50MHz clocked 16-bit parallel interface via separate optional 37 way MDM connector.

The small size eases the burden on UAV and AFV payloads in particular and the reduced power consumption renders a double benefit, as a smaller, lighter power supply is required. RF connections are made by SMA, DC Power, USB2 and 25 way MDM, parallel data uses an optional separate 37 way MDM connector

External 50 MHz clock input can be selected to operate the time of arrival (TOA) counter (shared clock source for the parallel data output PDWs), hence the PDWs generated will have fully correlated TOA digits.

## Global Defence & Security Solutions

Teledyne Defence Ltd  
Airedale House  
Royal London Industrial Estate  
Acorn Park, Charlestown  
Shipley, West Yorkshire  
UK, BD17 7SW

Tel: +44 (0) 1274 531 602  
Fax: +44 (0) 1274 595 724  
Email: [sales@fcl.com](mailto:sales@fcl.com)  
Web: [www.teledyne.com](http://www.teledyne.com)

**RR017**  
02 July 2008  
Page 1 of 8



Electrical Specification - -40°C to +85°C

Parameter	Specification
Operating Frequency	2 to 18 GHz
Out of Band Rejection	DC to 1.5 GHz > 40 dB 20 to 26 GHz > 30 dB
Operating Dynamic Range - Digital attenuator unselected	-57 to -15 dBm (-60 dBm Typ)
Operating Dynamic Range - Digital attenuator selected	-37 to +5 dBm
Frequency Measurement Coding	1900+25xCode MHz
Frequency Measurement Resolution	10 bits 25 MHz nom.
Frequency Measurement Accuracy	
over operating dynamic range	<15 MHz r.m.s.
Minimum Pulse Width	75 nsec
Frequency Measurement Triggering	Internal
Pulse Width & Time of Arrival Resolution	10 nsec
Amplitude Measurement Resolution	9 bits 0.2dB nom
Amplitude Measurement Coding	-70 + 0.2 x Code dB
Amplitude Measurement Accuracy	<1.5dB RMS
Amplitude Measurement Tracking (Between video outputs at the Same Frequency, Temperature & Power level)	<0.5dB RMS
Amplitude Measurement Tracking (at same frequency and temperature, with less than 20dB difference between 2 signals)	<1.5dB rms
Pulse on Pulse performance (Simultaneous signal >10dB)	Yes see Note 1
Amplitude measurement Video Coupling	D.C Coupled
Recovery Time	500 nsec max
RF Input Switch Isolation. Inputs 1-2 and A-B	35 dB min
RF Input Switch Speed	<200 nsec
RF Input Switch Control	LVTTL
Input Return Loss, Ports A1,A2,B1,B2	7dB min (10dB typ)
Clock Input (req'd if using Parallel data port or Time Of Arrival Correlation)	50 MHz
Dimensions	153x 153 x 19mm max.
Weight	800 grams max
Microwave Input Connectors	SMA Female
Power and control	25 & 37 way MDM
Power Dissipation (operating)	15W target
Power Dissipation (Standby)	<0.5W
Power-up Time (From application of DC supplies)	<2 seconds
Power-up Time (from Standby)	<100ms

Note: 1 Minimum Frequency separation 100MHz, Leading edge separation >500ns.



## Block Diagram for RR017

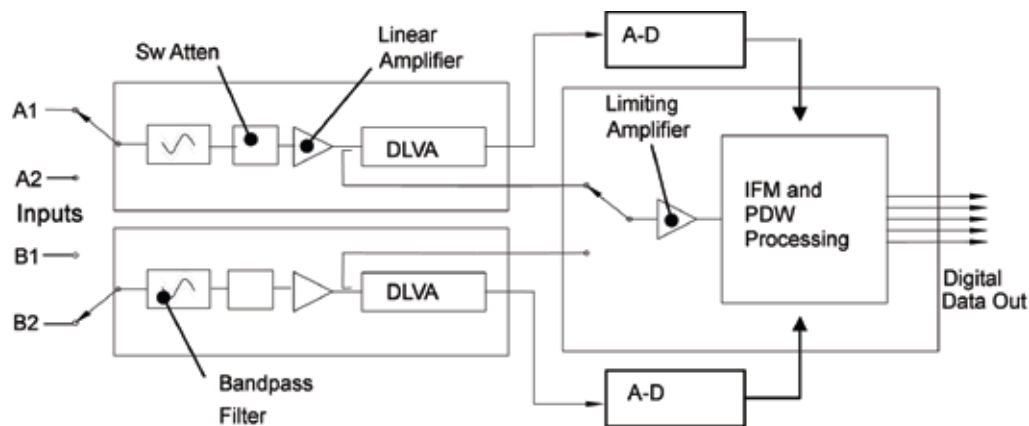

## Operating Modes

LVTTTL Control inputs are provided for direct control over the Input selection, the IFM measurement channel and the switched attenuator but in addition these functions may be controlled from the USB2 interface although this will introduce a delay dependant on the USB2 transfer time. An auto mode is available for the attenuator and the IFM channel to simplify the operation.

The IFM can be directed to either of the measurement channels by the use of a TTL or USB command or alternatively using Auto Freq mode the internal thresholding will determine the amplitude channel with the highest signal and route the IFM accordingly. This process will function on a pulse-by-pulse basis but will reduce the minimum pulse width to 120ns due to the switching delay. The mode of operation can be specified from the USB2 interface and can be changed as required.

The switched attenuator can be introduced, to both channels simultaneously, to enable the amplitude of high level signals to be measured. This can be manually controlled or using Auto Atten mode the system will detect on over-range measurement and switch the attenuation automatically. This process will function on a pulse-by-pulse basis but will reduce the minimum pulse width to 200ns due to the switching delay.

The unit generates a PDW following the end of a received pulse, the maximum reported pulse width is 650µs. Under CW conditions a PDW is generated after a pre-settable time, up to the maximum 650µs with the CW Present flag set, PDW's will continue to be generated with the same interval for the duration of the CW signal.



## Pulse Descriptor Word Format

The PDW is transmitted as either 6 x 16bit parallel words using the parallel data port or a single USB2 data packet with 96 bits. multi-function unit.

Data Words			
	1/2	3/4	5/6
0	Frequency 0	Pulse Width 0	Time of Arrival 0
1	Frequency 1	Pulse Width 1	Time of Arrival 1
2	Frequency 2	Pulse Width 2	Time of Arrival 2
3	Frequency 3	Pulse Width 3	Time of Arrival 4
4	Frequency 4	Pulse Width 4	Time of Arrival 4
5	Frequency 5	Pulse Width 5	Time of Arrival 5
6	Frequency 6	Pulse Width 6	Time of Arrival 6
7	Frequency 7	Pulse Width 7	Time of Arrival 7
8	Frequency 8	Pulse Width 8	Time of Arrival 8
9	Frequency 9	Pulse Width 9	Time of Arrival 9
10	Reserved	Pulse Width 10	Time of Arrival 10
11	Reserved	Pulse Width 11	Time of Arrival 11
12	Amplitude CHA 0	Pulse Width 12	Time of Arrival 12
13	Amplitude CHA 1	Pulse Width 13	Time of Arrival 13
14	Amplitude CHA 2	Pulse Width 14	Time of Arrival 14
15	Amplitude CHA 3	Pulse Width 15	Time of Arrival 15
0	Amplitude CHA 4	POP Present CHA	Time of Arrival 16
1	Amplitude CHA 5	POP Present CHB	Time of Arrival 17
2	Amplitude CHA 6	CW present	Time of Arrival 18
3	Amplitude CHA 7	Ambiguity Bad Data	Time of Arrival 19
4	Amplitude CHA 8	Threshold Bad Data	Time of Arrival 20
5	Reserved	Active IFM Channel	Time of Arrival 21
6	Amplitude CHB 0	Ant Select 0 state	Time of Arrival 22
7	Amplitude CHB 1	Ant Select 1 state	Time of Arrival 23
8	Amplitude CHB 2	Re-Measure state	Time of Arrival 24
9	Amplitude CHB 3	Auto Freq state	Time of Arrival 25
10	Amplitude CHB 4	Auto Atten state	Time of Arrival 26
11	Amplitude CHB 5	Reserved	Time of Arrival 27
12	Amplitude CHB 6	Reserved	Time of Arrival 28
13	Amplitude CHB 7	Reserved	Time of Arrival 29
14	Amplitude CHB 8	Reserved	Time of Arrival 30
15	Reserved	Reserved	Time of Arrival 31



## Connector Information: PSU & Control 25 way MDM

Pin	Signal	Direction	Description
1	USBDM	PBi-dir	TBi-dir USB Data Minus
2	USB_Vcc	USB Power	Power from host USB controller
3	Re-Measure	Input - LVTTTL <sup>3</sup>	Initiate manual measurement
4	Reserved Input	Input - LVTTTL <sup>3</sup>	Spare Logic Input
5	Antenna Select(0)	Input - LVTTTL <sup>3</sup>	Antenna Channel A Select
6	CLK_IN-	Input - LVDS	Master Clock Input 1
7	IFM Channel Select	Input - LVTTTL <sup>3</sup>	IFM Channel Select
8	Reserved output	Output - LVTTTL	Spare Output Logic
9	+VCC <sup>4</sup>	Power	
10	GND	Power	Ground
11	+5V	Power	
12	GND	Power	
13	+3.3V	Power	
14	USBDP	Bi-dir	USB Data Plus
15	PWRDN#	Input - LVTTTL <sup>3</sup>	Initiates Low Power Mode
16	DGND	Ground	Digital Ground
17	Attenuator	Input - LVTTTL <sup>3</sup>	Attenuator Control
18	Antenna Select(1)	Input - LVTTTL <sup>3</sup>	Antenna Channel B Select
19	CLK_IN+	Input - LVDS	Master Clock Input 1
20	Reserved 1	Input	Input
21	GND	Power	Ground
22	-VEE <sup>2</sup>	Power	
23	GND	Power	Ground
24	GND	Power	Ground
35	+3.3V	Power	

<sup>1</sup> This pin is reserved for FDL and must be left floating for normal unit operation.

<sup>2</sup> -VEE to be confirmed between -5V and -12V supply.

<sup>3</sup> LVTTTL inputs are +5V tolerant.

<sup>4</sup> +VCC to be confirmed between +6V and +12V supply. However, the +Vcc input may not be required at all.



Parallel Interface 37 Way MDM (Optional)

Pin	Signal	Direction	Description
1	CLK_IN+	Input - LVDS	Master Clock Input 2
2	DataSync+	Output -LVDS	Data Sync
3	Data(0)+	Output -LVDS	Parallel Data Word
4	Data(1)+	Output -LVDS	Parallel Data Word
5	Data(2)+	Output -LVDS	Parallel Data Word
6	Data(3)+	Output -LVDS	Parallel Data Word
7	Data(4)+	Output -LVDS	Parallel Data Word
8	Data(5)+	Output -LVDS	Parallel Data Word
9	Data(6)+	Output -LVDS	Parallel Data Word
10	Data(7)+	Output -LVDS	Parallel Data Word
11	Data(8)+	Output -LVDS	Parallel Data Word
12	Data(9)+	Output -LVDS	Parallel Data Word
13	Data(10)+	Output -LVDS	Parallel Data Word
14	Data(11)+	Output -LVDS	Parallel Data Word
15	Data(12)+	Output -LVDS	Parallel Data Word
16	Data(13)+	Output -LVDS	Parallel Data Word
17	Data(14)+	Output -LVDS	Parallel Data Word
18	Data(15)+	Output -LVDS	Parallel Data Word
19	DGND	Ground	Digital Ground
20	CLK_IN-	Input - LVDS	Master Clock Input 2
21	DataSync-	Output - LVDS	Data Sync
22	Data(0)+	Output -LVDS	Parallel Data Word
23	Data(1)+	Output -LVDS	Parallel Data Word
24	Data(2)+	Output -LVDS	Parallel Data Word
25	Data(3)+	Output -LVDS	Parallel Data Word
26	Data(4)+	Output -LVDS	Parallel Data Word
27	Data(5)+	Output -LVDS	Parallel Data Word
28	Data(6)+	Output -LVDS	Parallel Data Word
29	Data(7)+	Output -LVDS	Parallel Data Word
30	Data(8)+	Output -LVDS	Parallel Data Word
31	Data(9)+	Output -LVDS	Parallel Data Word
32	Data(10)+	Output -LVDS	Parallel Data Word
33	Data(11)+	Output -LVDS	Parallel Data Word
34	Data(12)+	Output -LVDS	Parallel Data Word
35	Data(13)+	Output -LVDS	Parallel Data Word
36	Data(14)+	Output -LVDS	Parallel Data Word
37	Data(15)+	Output -LVDS	Parallel Data Word



Outline Drawing for **RR017**

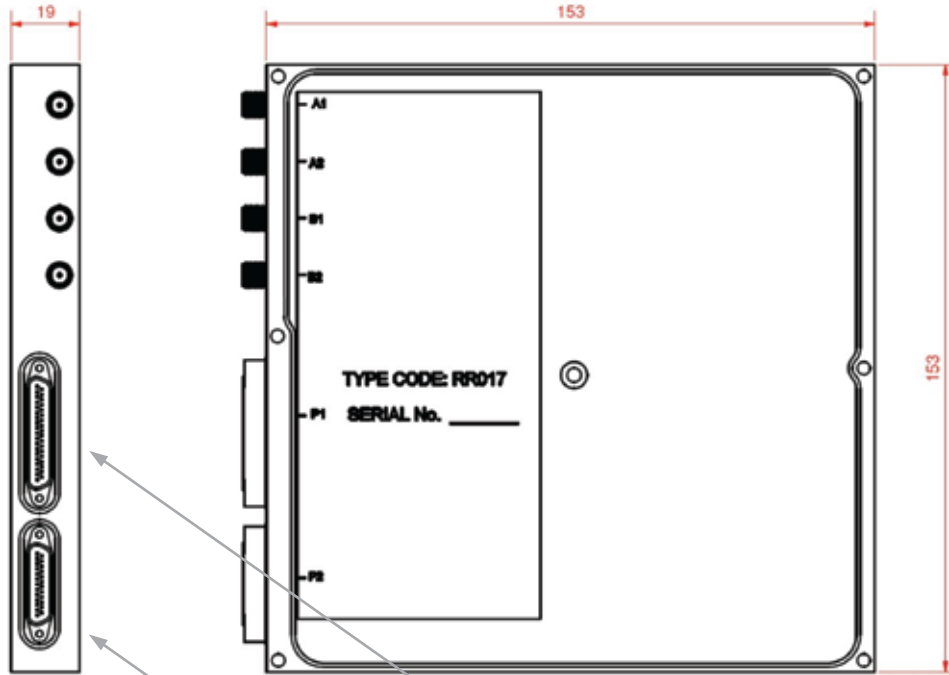

25 way MDM DC, control and USB2 data

Optional 37 way MDM fitted if required

Parallel Data transfer (optional)

Each PDW will be transferred in eight clock cycles.  
The diagram below illustrates a full transfer plus the start of the next transfer.

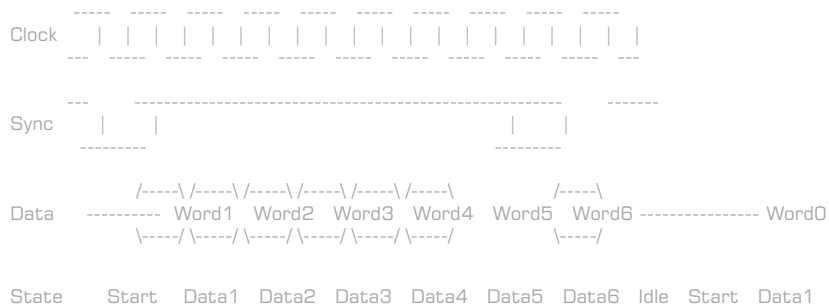



**TELEDYNE  
DEFENCE LIMITED**

A Teledyne Technologies Company

2-18GHz Radar Warning  
Receiver  
**RR017**

Teledyne Defence Ltd  
Airedale House  
Royal London Industrial Estate  
Acorn Park  
Charlestown  
Shipley, West Yorkshire  
UK, BD17 7SW

Tel: +44 (0) 1274 531 602  
Fax: +44 (0) 1274 595 724  
Email: [sales@fcl.com](mailto:sales@fcl.com)  
[www.teledyne.com](http://www.teledyne.com)